

ES-749

- “EZ Setup”- Guided Setup for First Time Users
- Liquid, Gas, Steam and Heat Flow Equations
- Utility Metering - Steam, Heating/Cooling, Chilled Water, Natural Gas, Compressed Air
- Menu Selectable Hardware & Software Features
- Internal Data Logger
- Isolated Pulse and Analog Outputs Standard
- RS-232 Port Standard, Provides Power for Modem
- RS-485 Optional
- Windows™ Setup Software
- NX19 Gas Equations, Stacked DP Transmitters
- DDE Server & HMI Software Available

Description:

The ES-749 Flow Computer satisfies the instrument requirements for a variety of flowmeter types in liquid, gas, steam and heat applications. Multiple flow equations are available in a single instrument with many advanced features.

The alphanumeric display offers measured parameters in easy to understand format. Manual access to measurements and display scrolling is supported

The versatility of the Flow Computer permits a wide measure of versatility within the instrument package. The various hardware inputs and outputs can be “soft” assigned to meet a variety of common application needs. The user “soft selects” the usage of each input/output while configuring the instrument.

Applications Include:

Steam Mass, Steam Heat, Natural Gas, Fuel Oil, Compressed Air, Chilled Water Only, Heated Water Only including Low DeltaT Cutout.

The isolated analog output can be chosen to follow the volume flow, corrected volume flow, mass flow, heat flow, temperature, pressure, or density by means of a menu selection. Most hardware features are assignable by this method.

The user can assign the standard RS-232 Serial Port for external data logging, transaction printing, or for connection to a modem for remote meter reading.

A Service or Test mode is provided to assist the user during start-up system check out by monitoring inputs and exercising outputs. The system setup can also be printed.

Utility Metering Flow Computer



- Remote Metering by External Wireless or Modem
- Attractive Wall Mount Enclosure Available

Specifications:

Environmental

Operating Temperature: 0 to +50 C
Storage Temperature: -40 to +85 C
Humidity : 0-95% Non-condensing
Materials: UL, CSA, VDE approved

Display

Type: 2 lines of 20 characters
Types: Backlit LCD and VFD ordering options
Character Size: 0.3” nominal
User selectable label descriptors and units of measure

Keypad

Keypad Type: Membrane Keypad
Keypad Rating: Sealed to Nema 4
Number of keys: 16

Enclosure

Enclosure Options: Panel, Wall, Explosion Proof
Size: See Dimensions
Depth behind panel: 6.5” including mating connector
Type: DIN
Materials: Plastic, UL94V-0, Flame retardant
Bezel: Textured per matt finish

Power Input

The factory equipped power option is internally fused. An internal line to line filter capacitor is provided for added transient suppression. MOV protection for surge transient is also supported
Universal AC Power: 85 to 276 Vrms, 50/60 Hz
DC Power Option: 24 VDC (16 to 48 VDC)
Power Consumption
AC Power: 6.5 V/A
DC Power: 300 mA max.

990239 01/28/11

Flow Meter Types:

Linear: Vortex, Turbine, Positive Displacement, Magnetic, GilFlo, ILVA, Mass Flow and others
Square Law: Orifice, Venturi, Nozzle, V-Cone, Wedge, Averaging Pitot, Target, Verabar, Accelabar and others
Multi-Point Linearization: May be used with all flowmeter types. Including: 16 point, UVC and dynamic compensation.

Flow Inputs:

Analog Input:

Accuracy: 0.02% FS at 20° C

Ranges

Voltage: 0-10 VDC, 0-5 VDC, 1-5 VDC

Current: 4-20 mA, 0-20 mA,
4-20 mA stacked, 0-20 mA stacked

Basic Measurement Resolution: 16 bit

Update Rate: 4 updates/sec

Automatic Fault detection: Signal over/under-range,
Current Loop Broken

Calibration: Operator assisted learn mode

Extended calibration: Learns Zero and Full
Scale of each range

Fault Protection:

Fast Transient: 500 V Protection (capacitive
clamp)

Reverse Polarity: No ill effects

Over-Voltage Limit: 50 VDC Over voltage
protection

Over-Current Protection: Internally current limited
protected to 24VDC

Pulse Inputs:

Number of Flow Inputs: one

Input Impedance: 10 k Ω nominal

Trigger Level: (menu selectable)

High Level Input

Logic On: 2.5 to 30 VDC

Logic Off: 0 to 2 VDC

Low Level Input (mag pickup)

Selectable sensitivity: 10 mV and 100 mV

Minimum Count Speed: 0.25 Hz (to maintain rate
display)

Maximum Count Speed: Selectable: 0 to 50 kHz

Overvoltage Protection: 50 VDC

Temperature, Pressure, Density Inputs

The compensation inputs usage are menu selectable for temperature, temperature 2, pressure, density or not used.

Calibration: Operator assisted learn mode

Operation: Ratiometric

Accuracy: 0.02% FS at 20° C

Basic Measurement Resolution: 16 bit

Update Rate: 2 updates/sec minimum

Automatic Fault detection:

Signal Over-range/under-range

Current Loop Broken

RTD short

RTD open

Reverse Polarity: No ill effects

Over-Current Limit

(current input)Internally limited to protect input to
24 VDC)

Available Input Ranges

Current: 4-20 mA, 0-20 mA

Resistance: 100 Ohms DIN RTD

100 Ohm DIN RTD (DIN 43-760, BS 1904):

Three Wire Lead Compensation

Internal RTD linearization learns ice point
resistance

1 mA Excitation current with reverse polarity
protection

Temperature Resolution: 0.1° C

Temperature Accuracy: $\pm 0.5^\circ$ C

Stored Information (ROM)

Steam Tables (saturated & superheated),

Fluid Properties: Water, Air, Natural Gas or Generic

User Entered Stored Information (EEPROM / Nonvolatile RAM)

Transmitter Ranges, Signal Types

Fluid Properties

(specific gravity, expansion factor, specific heat,
viscosity, isentropic exponent, combustion heating
value, Z factor)

Units Selections (English/Metric)

Language Translations (optional)

Excitation Voltage

24 VDC @ 100 mA (fault protected)

Relay Outputs

The relay outputs usage is menu assignable to (Individually for each relay) Hi/Lo Rate Alarm, Hi/Lo Temperature Alarm, Hi/Lo Pressure Alarm, Pulse Output (pulse options), Wet Steam or General purpose warning (security).

Number of relays: 2 (3 optional)
Contact Style: Form C contacts
Contact Ratings: 240 V, 5 amp

Analog Outputs

The analog outputs are menu assignable to correspond to the Uncompensated Volume Rate, Corrected Volume Rate, Mass Rate, Heat Rate, Temperature, Density, or Pressure.

Number of Outputs: 2
Type: Isolated Current Sourcing (shared common)
Available Ranges: 0-20 mA, 4-20 mA (menu selectable)
Resolution: 16 bit
Accuracy: 0.05% FS at 20 Degrees C
Update Rate: 5 updates/sec
Temperature Drift: Less than 200 ppm/C
Maximum Load: 1000 ohms
Compliance Effect: Less than .05% Span
60 Hz rejection: 40 dB minimum
EMI: No effect at 3 V/M
Calibration: Operator assisted Learn Mode
Averaging: User entry of DSP Averaging constant to cause a smooth control action

Listing: CE Approved, UL/CSA Pending

Serial Communication

The serial port can be used for printing, datalogging, modem connection and communication with a computer. Power is provided for KEP's MPP2400N (modem) communication accessory.

RS-232:

Device ID: 01-99
Baud Rates: 300, 1200, 2400, 9600
Parity: None, Odd, Even
Handshaking: None, Software, Hardware
Print Setup: Configurable print list and formatting,
Compatible with external dataloggers.

RS-485:

Device ID: 01-247
Baud Rates: 300, 600, 1200, 2400, 4800, 9600,
19200
Parity: None, Odd, Even
Protocol: Modbus RTU (Half Duplex)

Data Logging

The data logger captures print list information to internal

storage for approximately 5000 transactions. This information can be used for later uploading or printing. Storage format is selectable for Comma-Carriage Return or Printer formats.

Isolated Pulse output

The isolated pulse output is menu assignable to Uncompensated Volume Total, Compensated Volume Total, Heat Total or Mass Total.

Pulse Output Form (menu selectable): Open Collector NPN or

24 VDC voltage pulse

Nominal On Voltage: 24 VDC

Maximum Sink Current: 25 mA

Maximum Source Current: 25 mA

Maximum Off Voltage: 30 VDC

Saturation Voltage: 0.4 VDC

Pulse Duration: User selectable

Pulse output buffer: 8 bit

Fault Protection

Reverse polarity:

Shunt Diodes

Over-current Protected

Over-voltage Protected

Real Time Clock

The Flow Computer is equipped with a non-volatile real time clock with display of time and date.

Format:

24 hour format for time

Day, Month, Year for date

Dimensions

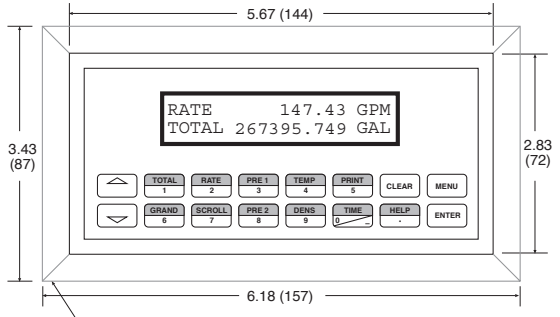

Dotted Line Shows Optional Bezel Kit

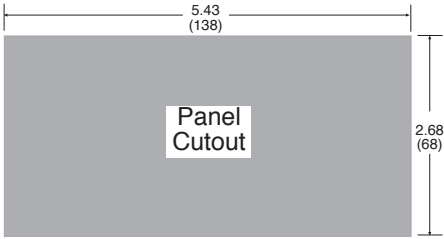
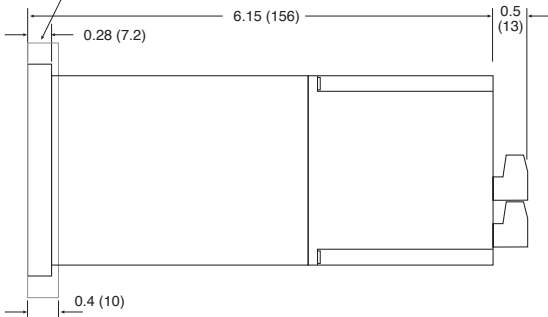

Dimensions are in inches (mm)

Wall Mount (option W)

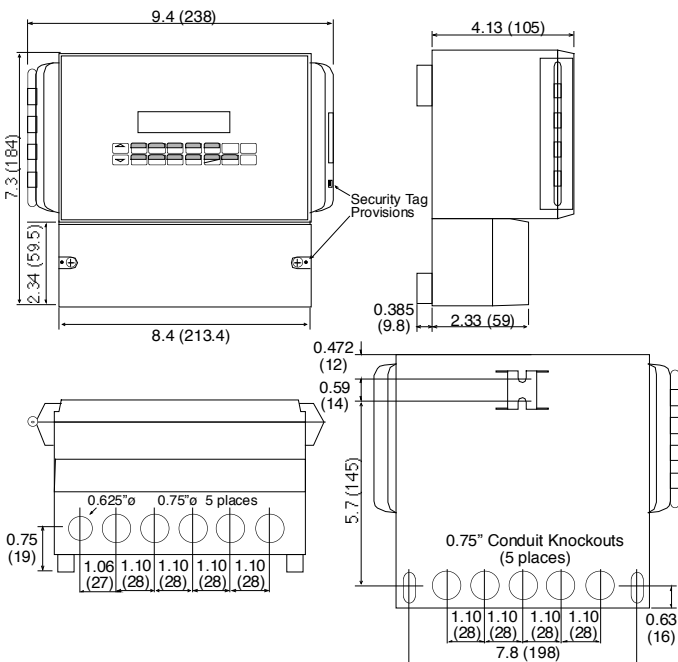

Terminal Designations

1	DC OUTPUT	17	NO	
2	PULSE IN	18	COM RLY1	
3	Vin (+)	19	NC	
4	lin (+)	20	NC	
5	COMMON	21	COM RLY2	
6	RTD EXCIT (+)	22	NO	
7	RTD SENS (+)	23	AC LINE	DC (+)
8	RTD SENS (-)	24	AC LINE	DC (-)
9	DC OUTPUT			
10	RTD EXCIT (+)			
11	RTD SENS (+)			
12	RTD SENS (-)			
13	PULSE OUTPUT (+)			
14	PULSE OUTPUT (-)			
15	ANALOG OUTPUT 1 (+)			
16	ANALOG OUTPUT 2 (+)			
	ANALOG OUTPUT COMMON (-)			
	TEMPERATURE IN			
	FLOW IN			
	TEMPERATURE IN			
	PRESSURE (TEMP 2) IN			
	POWER IN			

Ordering Information

Example **ES749** **L** **1** **0** **P** **TU**

Series: **ES749ST2 = ST2 Special**

Display Type: **L = LCD**
V = VFD

Input Type: **1 = 85 to 276 VAC**
3 = 24 VDC

Network Card: **0 = None**
1 = RS485/Modbus

Mounting: **P = Panel Mount**
***N = NEMA 4 Wall Mount (see MS811 NEMAtr0l)**
***W = NEMA 12/13 Wall Mount w/ Clear Cover**
***E = Explosion Proof (No Button Access)**
***X = Explosion Proof (with Button Access)**

- Options:
- 1 = Peak Demand
 - 2 = AGA NX-19 calculation for natural gas
 - 3 = Three Relays
 - 4 = Stacked DP option
 - 5 = Datalogger option (consult factory)
 - 6 = Stack Emissions Controller option
 - 7 = Manifold Flowmeter Controller option
 - 9 = 3 Relay Super Chip (options 1, 2, 4, 6,7)
 - 10 = 2 Relay Super Chip (options 1, 2, 4, 6,7)
 - 13 = Superchip; 2 relay, Positive heat only
 - 14 = Superchip; 3 relay, Positive heat only
 - 22 = Superchip; 2 relay, For use with 4 terminal multi-variable vortex meters
 - 26 = Superchip; 3 relay, For use with 4 terminal multi-variable vortex meters
- IM = IM-2400 Internal Modem
 - IM-56K = 56K Internal Secure Modem
 - M = Modem Power Option
 - ET = Extended Temperature LCD Display
 - TB = RS485 Terminal Block for Panel Mount Enclosure

- Accessories:
- KEPS-KEP1-32 KEP RS232 - 32 Bit DDE Server
 - KEPS-MBS32 Supports RS485 (Modbus RTU)
 - Modem Available, see MPP-56KN, and MPP-2400N
 - Serial printer available, see P1000, P295
 - Ethernet Port Server available, see IEPS
 - RS-422/485 to RS-232 Communication Adaptor available, see CA285
 - RS232 Extender Cable: P/N=13220-<length in inches>
 - Remote metering and data collection software available, see TROLink
 - ADAM-4572: Modbus RTU to Modbus TCP Converter